

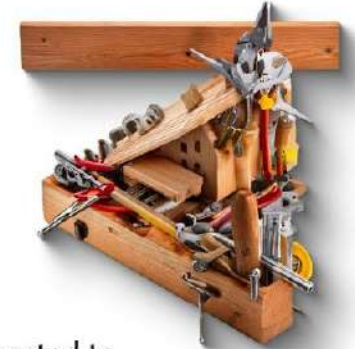

Welcome to Session By Technical Education and Skilling on Empowering Bengal: Nurturing Future Ready Skills For A High Precision Work Force

**BENGAL GLOBAL
BUSINESS SUMMIT**
5-6 February '25



Arijit Majumder

Arijit Majumder received B.Sc in Physics (Hons.) from University of Calcutta, the B.Tech degree in Radiophysics & Electronics from University of Calcutta & Ph.D degree from Jadavpur University.

After a short stint at IIT Bombay as a Research Associate, he joined SAMEER Mumbai as a scientist and was later posted to SAMEER Kolkata, where he is the Officer-In-Charge. He has more than 25 years of experience in Research and Development in RF, microwaves, and mm-wave technologies for strategic and civilian sectors. He is actively implementing various next-generation technologies for strategic and societal applications. He is also a lead researcher of multi-institutional collaborative research towards the development of indigenous 6G solutions as a part of the Bharat 6G alliance. He was a Visiting Scholar at the Packaging Research Center, Georgia Tech, Atlanta. He has contributed towards the design & development of indigenous MMIC technology and MMIC packaging up to 100 GHz. He has authored or coauthored in highly referred journals, including more than 50 publications in referred journals and conferences. His research interests include 6G technology, High-Frequency Device Modelling, MMIC, RFSOC, Communication & RADAR system frontends.



www.wbidc.com

Chamber Partners



Knowledge Partners



bengalglobalsummit.com



BENGAL means BUSINESS

Precision Engineering in Communication & RADAR Systems

Dr. Arijit Majumder (arijit.Sameer@nic.in)

SAMEER Kolkata Centre

MeitY, Govt. Of India

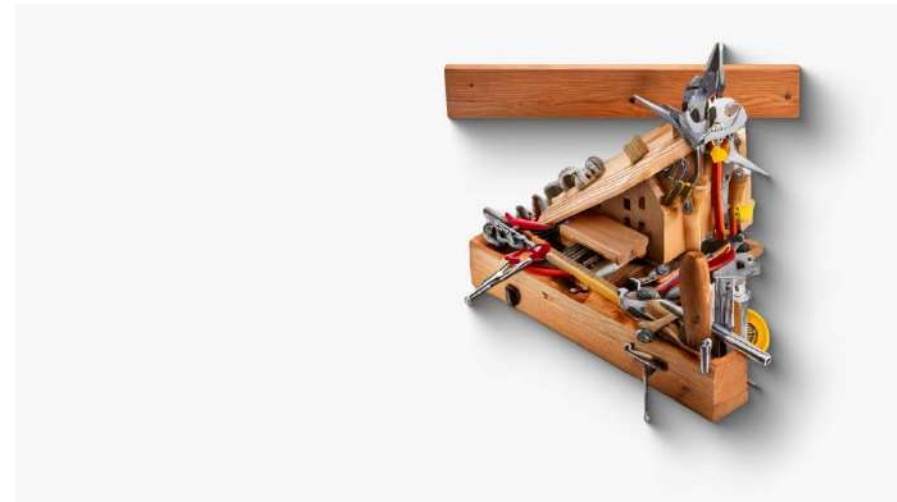



1993



1987



Centre for Microwave Research

SAMEER-Mumbai

1984



2017

SAMEER-Kolkata
Centre for Microwave & Millimeter Wave

SAMEER-Chennai
Centre for Electromagnetics

SAMEER-Vizag
Centre for Electromagnetic
Environmental Effects

SAMEER-Guwahati
Centre for High Power Electromagnetic
Tube & Components



2014

What is Precision Engineering

- Creation of highly precise component, structure or movement.
- Reduce the dispersion of the product's or part's function
 - Design and production of parts with tolerances measured in microns, that is one thousandth of a millimetre.
 - Production of parts with a substantial size-to-tolerance ratio.
 - Widely used across various industries including Automotive, Electronics, Medical, Semiconductor, Aerospace, Filtration etc.
 - Common precision engineering technologies include EUV Lithography, Electroforming, Photo Chemical Etching, Laser Micro Machining, Laser Cutting, Micro Stamping, etc.
- Improve Product Performance
- Increase Manufacturability
- Lower Costs
- Advances Science And Technology

Communication & RADAR Systems

- Includes Transmitter, Receiver, Radiating structures (Antennas), Signal Processing etc.
- Precision components needed for high accuracy systems
- Backend semiconductor technology is highly precise and miniaturised (4nm – 28 nm typically for digital and 250nm – 35nm for analog)
- Precision manufacturing for Mass production & Lowering of cost



MST RADAR at Gadanki



Seeker RADAR inside Missile

5G Base Station

6G : Spectrum Availability for Next generation Systems

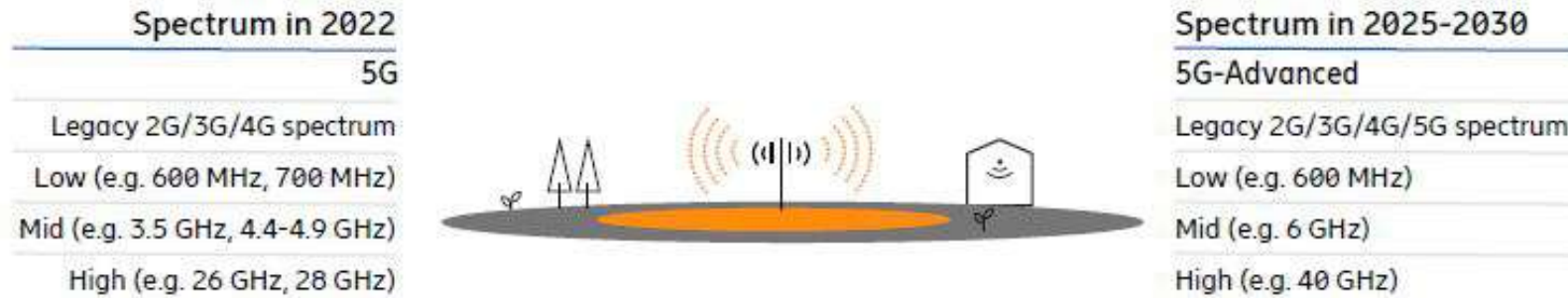

Spectrum availability from 2022 to 2030

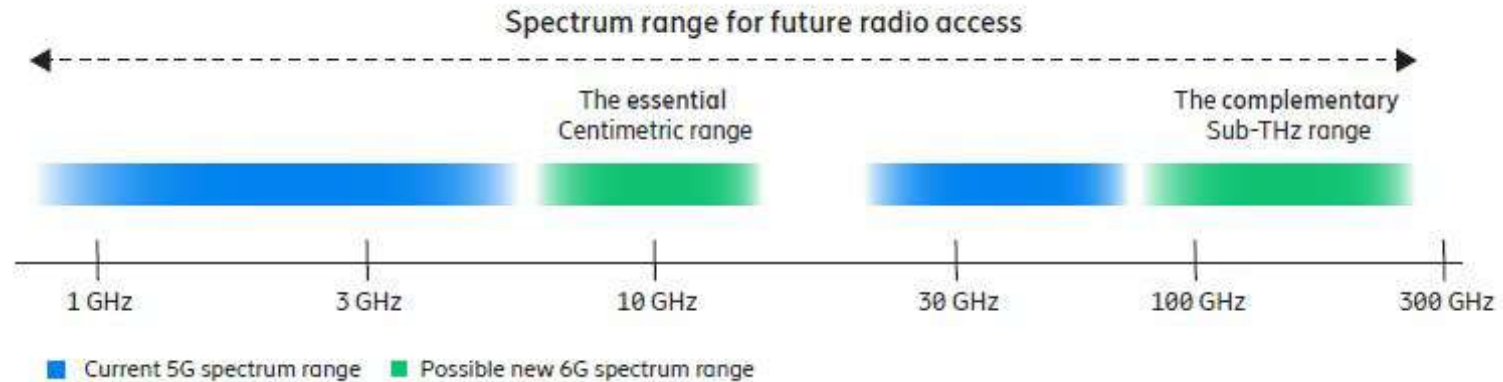

Possible new 6G spectrum ranges

Precision Engineering Examples

Medium Power Amplifier using InGaAs MHEMT (WR3) band)

35 nm InAlAs/InGaAs process by Fraunhofer IAF

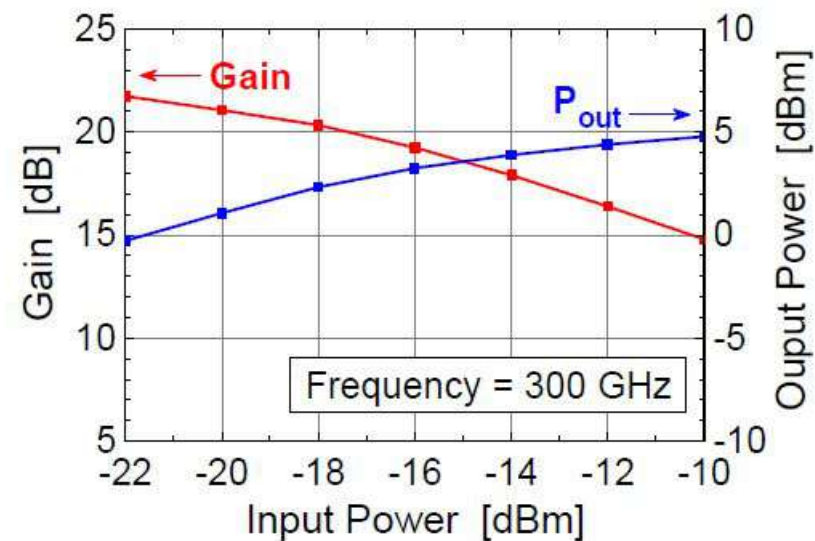
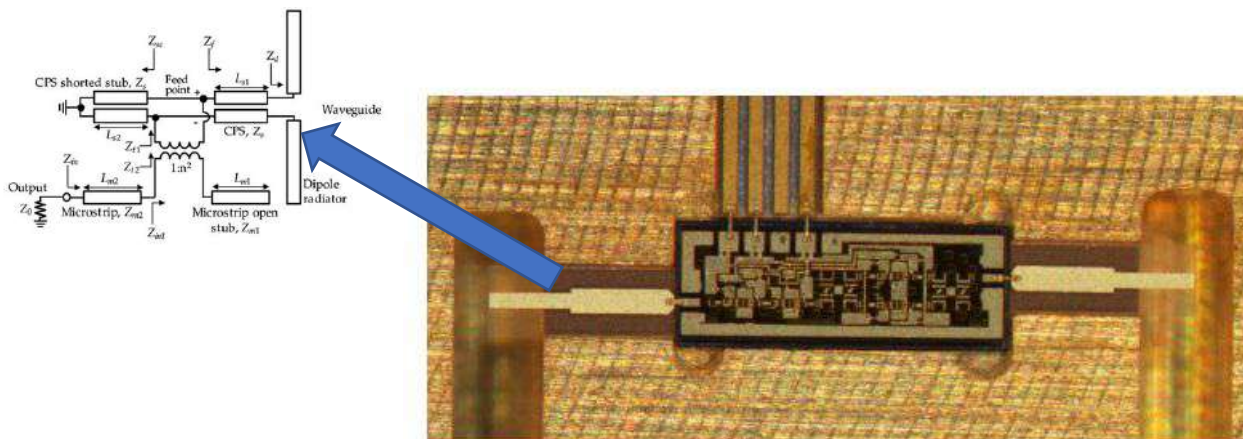
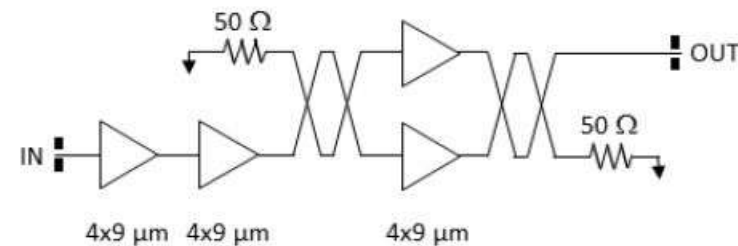
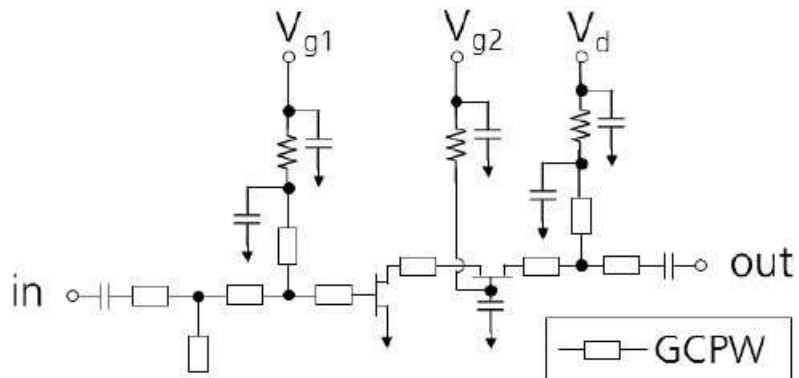

A Broadband 220-320 GHz Medium Power Amplifier Module, Kallfass et. al

MMIC Chipset using InGaAs MHEMT (WR3 band)

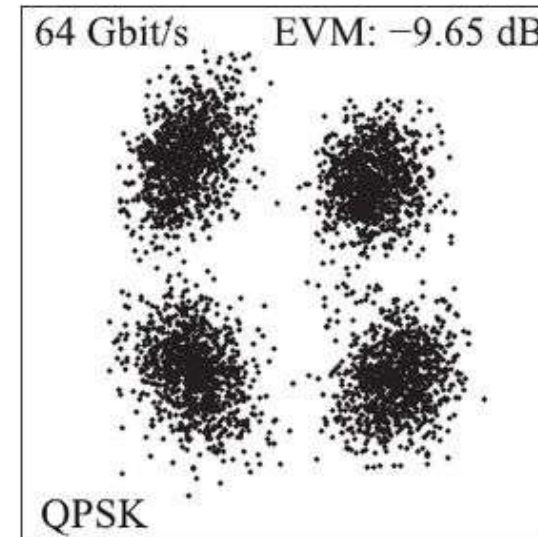
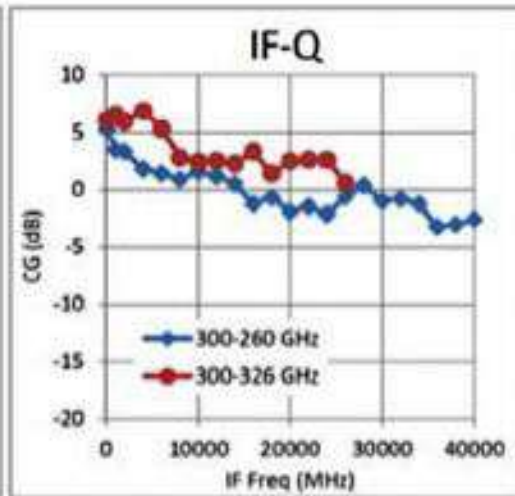
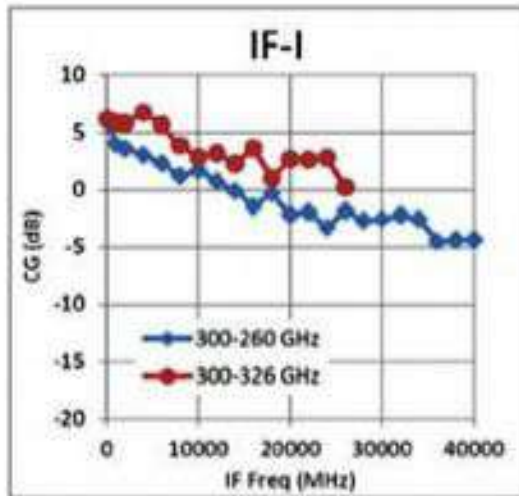
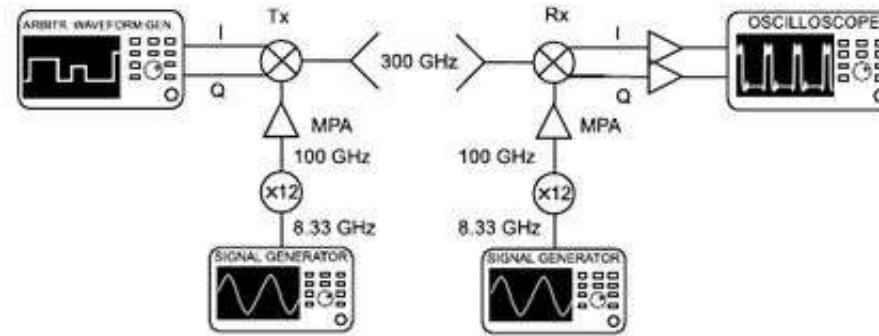
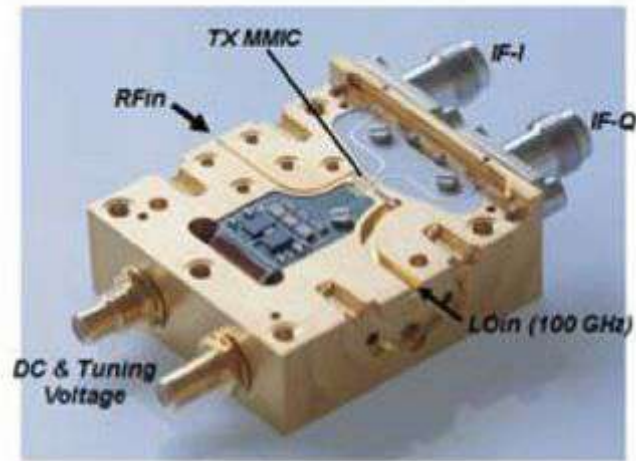

Precision Packaging

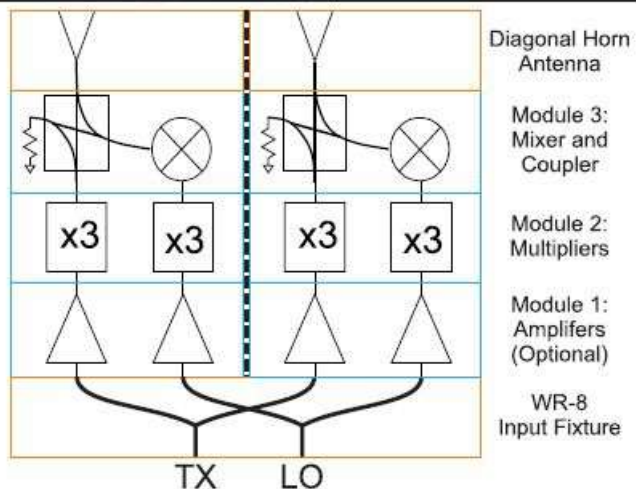
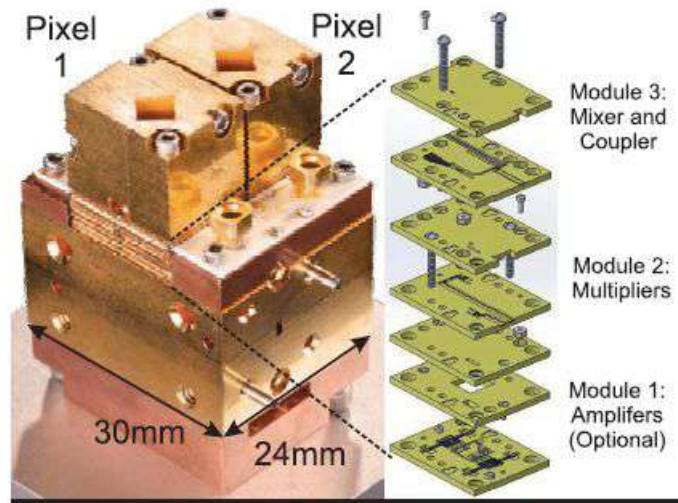

Vertically Stacked Heterodyne THz Array

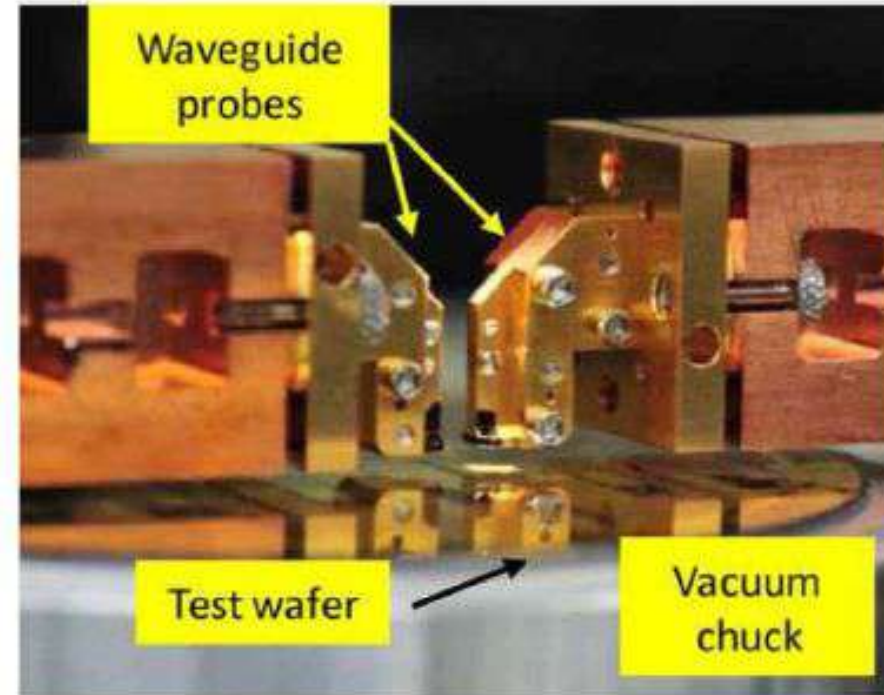

Precision Packaging

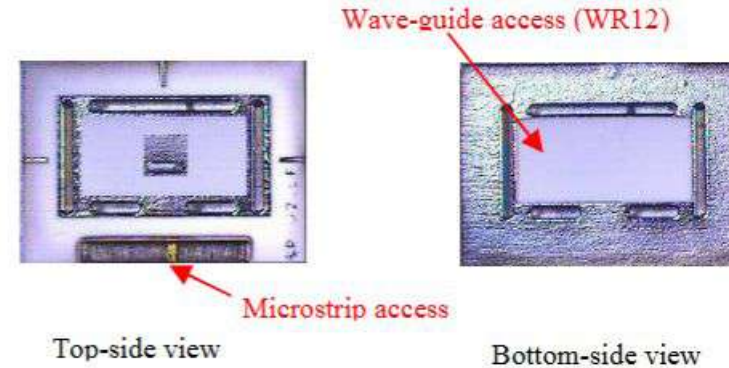
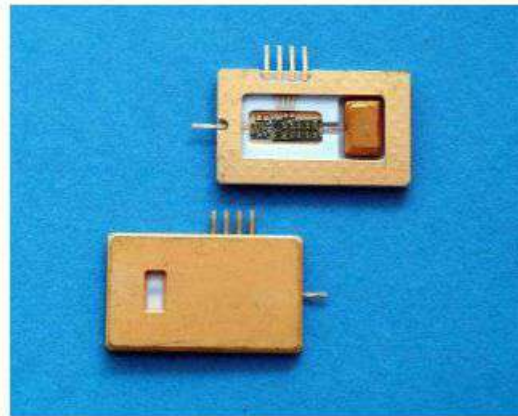

Ceramic and Organic Microstrip to Waveguide package at 77 GHz

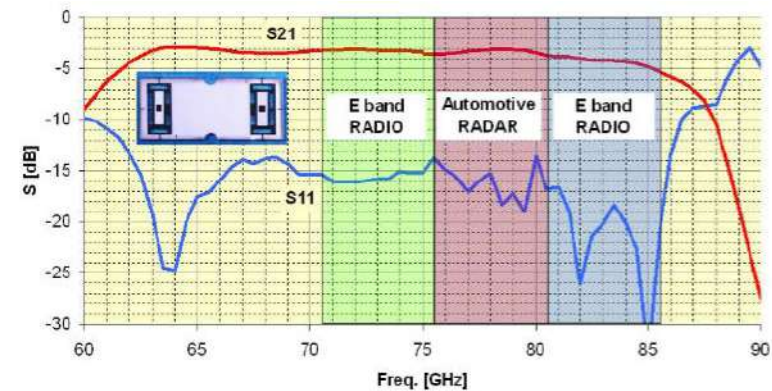
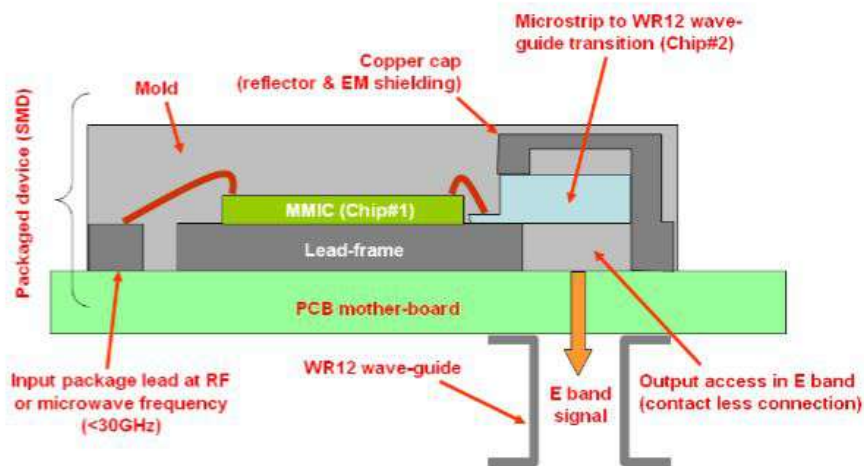

Millimeter-wave SMT Low Cost Plastic Packages for Automotive RADAR at 77GHz and High Data Rate E-band Radios, PF. Alléaume et. al.

Key Technology Development at SAMEER using Precision Engineering

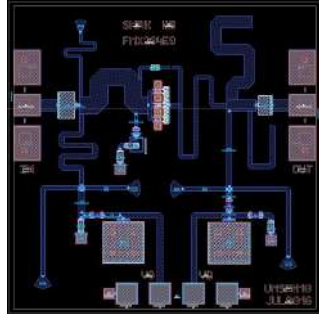

W-band Doubler

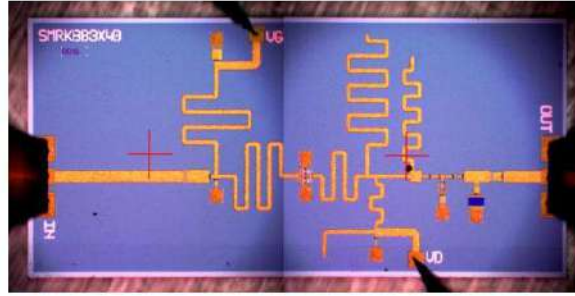

Quadrupler at 57 GHz

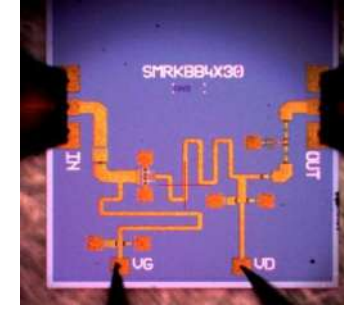

Tripler at 47 GHz

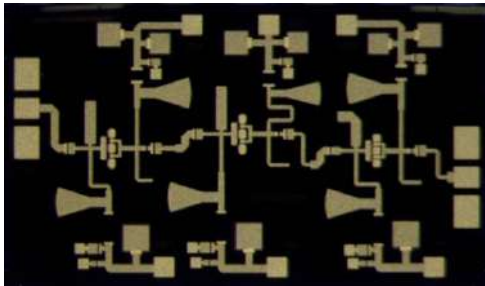

W-band LNA

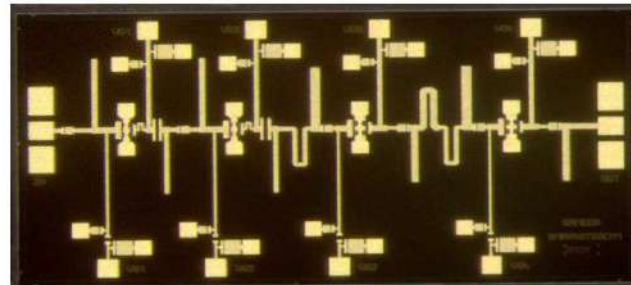

V-band Medium Power Amplifier

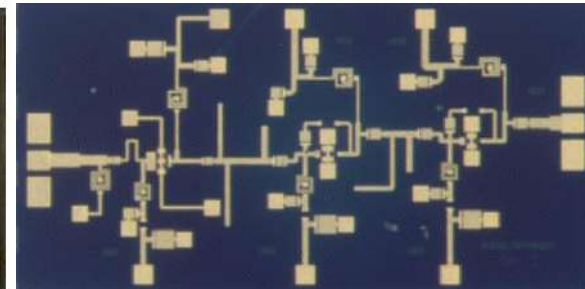

18-40 GHz LNA

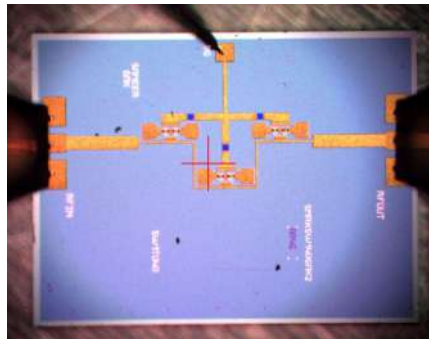

1-40 GHz SPST switch

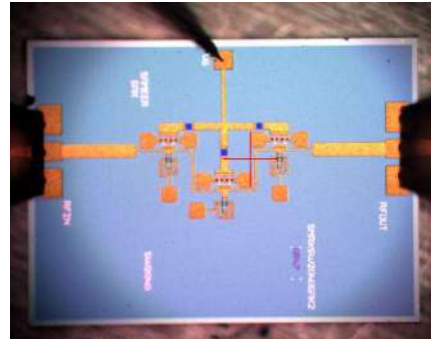

20-40 GHz SPST switch

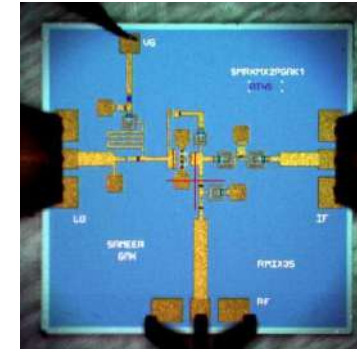

Ka-band Mixer

Key Technology Development at SAMEER using precision engineering



**Micro-strip to Waveguide
Transition in V band**

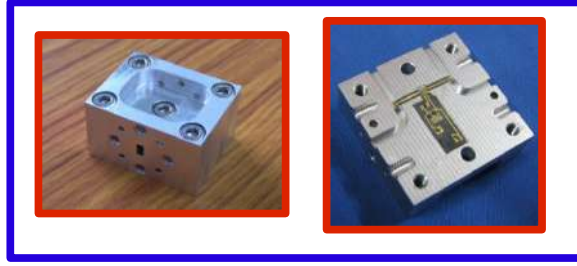

**MMIC Based V-Band Low
Noise Amplifier**

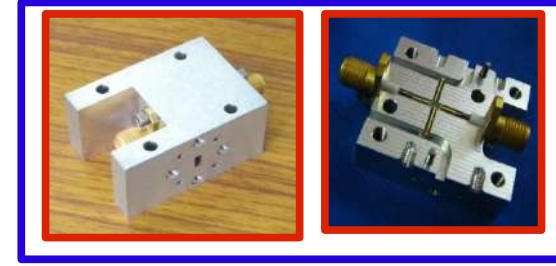

MMIC Based V-Band

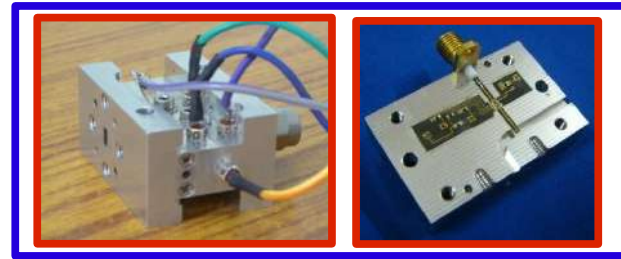

MMIC Based V-Band Quadrupler

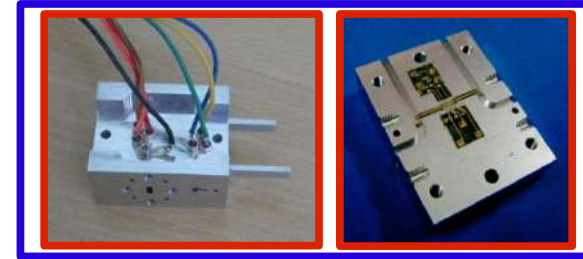

**MMIC Based V-Band
Medium Power Amplifier**

**Thank
You**